

Istruzioni per il montaggio
Assembly instructions
Instructions pour le montage
Montageanleitung
Instrucciones para el montaje

Design: Charles Kalpakian

WALL SHADOWS

GRAND LED

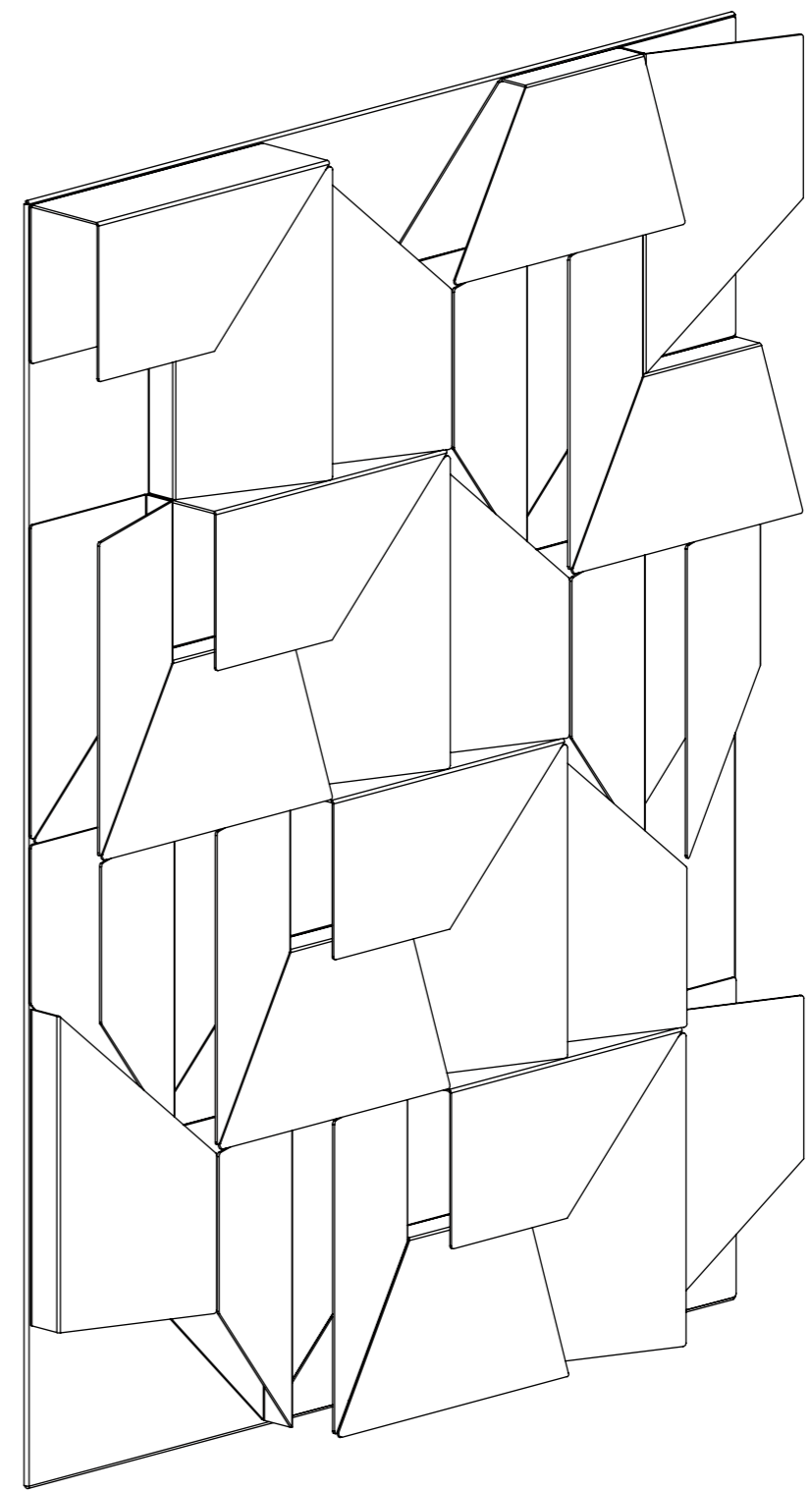



LED 55W, 5300lm, 240V/700mA CC, 3000°K, 50/60Hz



ITALIANO: Le descrizioni dei simboli relativi a questa lampada Si trovano sul foglio allegato.

ENGLISH: Descriptions of the symbols for this lamp can be found on the sheet enclosed.

FRANÇAIS: Les descriptions des symboles relatifs à cette lampe se trouvent sur le document ci-joint.

DEUTSCH: Die Beschreibungen für die Symbole, die auf diese Lampe bezogen sind, entnehmen Sie bitte dem beiliegenden Zettel.

ESPAÑOL: Las descripciones de los símbolos relativos a esta lámpada se encuentran en el folio adjuntado.

БЪЛГАРСКИ: Описанията на символите за тази лампа са в приложението.

ČEŠTINA: Popisy symbolů pro tuto lampu naleznete v příloženém listě.

DANSK: Beskrivelsen af de symboler; som angår denne lampe, finder på den vedlagte forklaring.

EESTI: Selle lambi kohta käivate sümbolite kirjeldused leiata kaasasolevalt lehel.

ΕΛΛΗΝΙΚΑ: ΕΛΛΗΝΙΚΑ: Τα σύμβολα του φωτιστικού ατού περιγράφονται στο συνημμένο φυλλάδιο.

HRVATSKI: Opisi simbola koji se odnose na to svjetiljku, nalaze se na priloženoj listi.

LATVISKI: Šīr lampas simbolu apraksts ir pievienotajā lapā.

LIETUVIU: Šios lempos simbolių aprašymai pateikiami pridėtame lape.

MAGYAR: A lámpával kapcsolatos jelek leírását lásd a mellékelt tájékoztatón.

NEDERLANDS: De beschrijving van de symbolen m.b.t. deze lamp bevindt zich op het blad in bijlage.

NORSK: Forklaringene på symbolene som gjelder for denne lampen finnes på vedlagte ark.

POLSKI: Opisy symboli dotyczących tej lampy zostały przytoczone w załączonej ulotce.

PORTUGUÊS: As descrições dos símbolos relativos a esta lâmpada encontram-se na página em anexo.

ROMÂNĂ: Descrierea simbolurilor referitoare la această lampă se găsește în foaia atașată.

SLOVENSKI: Opisi simbolov, ki se nanašajo na to svetilko, so na priloženem listu.

SLOVENČINA: Popis symbolov pre túto lampu je uvedený na priloženom hárkú papiera.

SUOMI: Tätä lampun koskevien symbolien selitykset löytyvät oheisesta liitteestä.

SVENSKA: Beskrivningarna av symbolerna som gäller denna lampas finns att läsa på det bifogade informationsbladet.

NEMO



This luminaire contains built-in LED lamps.

Questo dispositivo è munito di lampade a LED integrate.

Diese Leuchte enthält eingebaute LED-Lampen.

Ce luminaire comporte des lampes à LED intégrées.

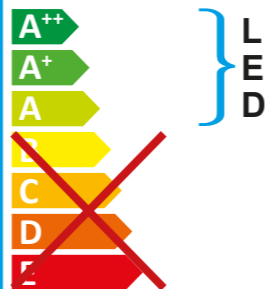

This luminaire is sold with a bulb of the energy class: **A+**

Il dispositivo è venduto con una lampadina di classe energetica: **A+**

Diese Leuchte wird verkauft mit einem Leuchtmittel der Energieklasse: **A+**

Le luminaire est vendu avec une ampoule de la classe énergétique: **A+**

The lamps cannot be changed in the luminaire.

Le lampade di questo dispositivo non sono sostituibili.

Die Lampen können in der Leuchte nicht ausgetauscht werden.

Les lampes de ce luminaire ne peuvent pas être changées.

874/2012



contenuto imballo - box contents - packungsinhalt - contenu de l'emballage - contenido de la confección

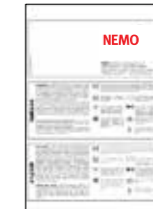
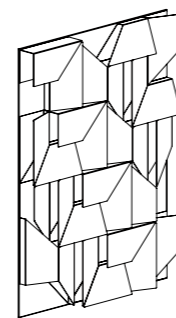

installazione - installation - installation - installation - instalación

1

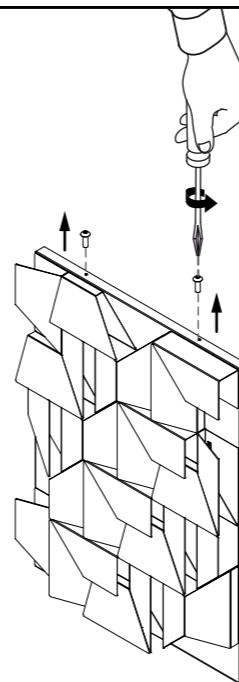

2

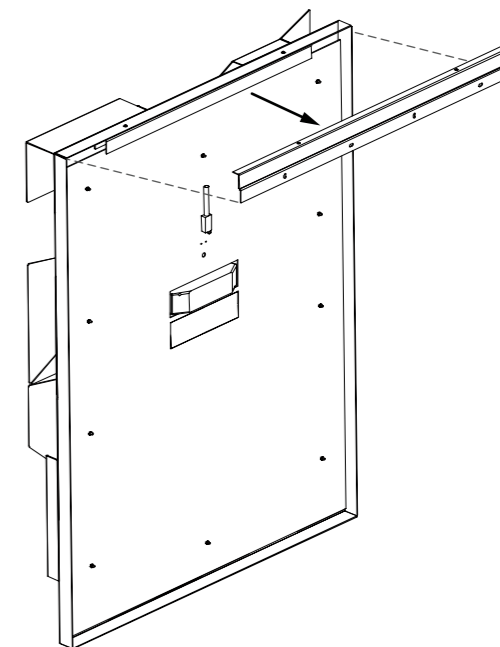

3

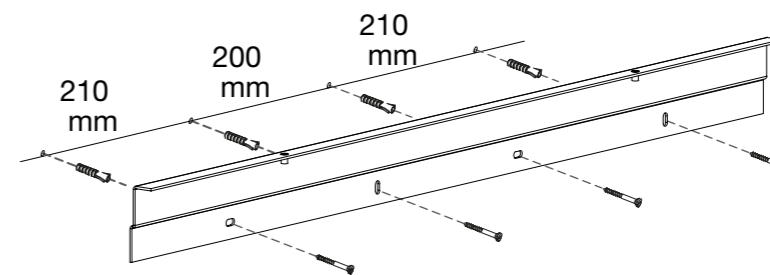

Tasselli non inclusi
Fischer not included

4

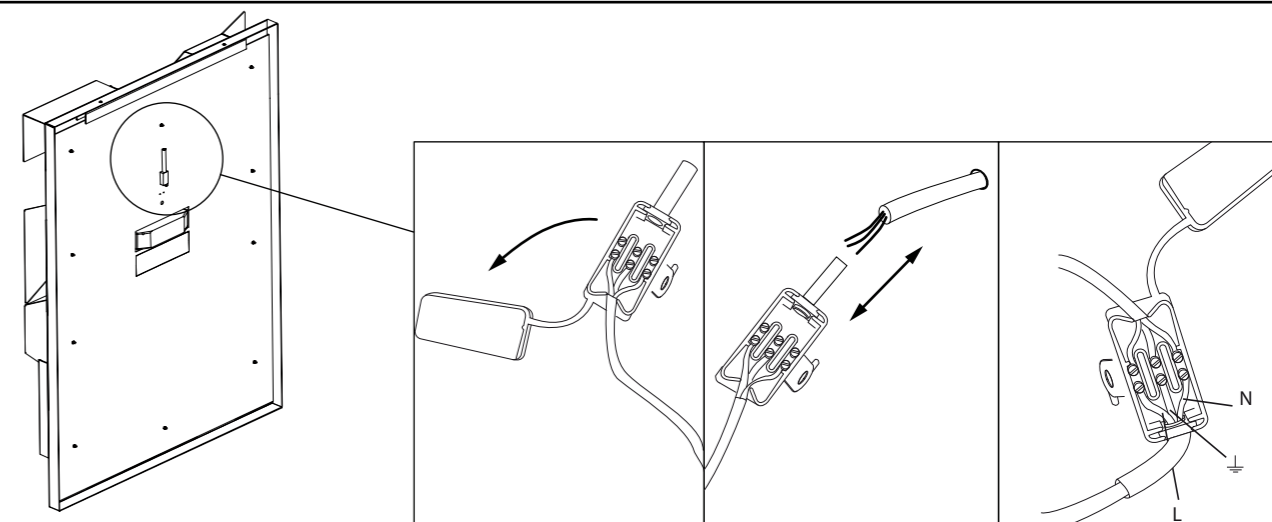

NEMO

Nemo S.r.L. Viale Brianza, 30 | 20823 Lentate sul Seveso (MB), Italy | Tel. +39 0362 166 05 00 | Fax +39 0362 372 996
info@nemolighting.com | nemolighting.com