

DAYTONA™ SQUARE

SUSPENSION

TYPE:

PROJECT NAME:



SPECIFICATION SHEET

Luminart®

WWW.LUMINARTLIGHTING.COM

DAYTONA™ SQUARE 600

SUSPENSION - OPAL DIFFUSER

TYPE:

PROJECT NAME:

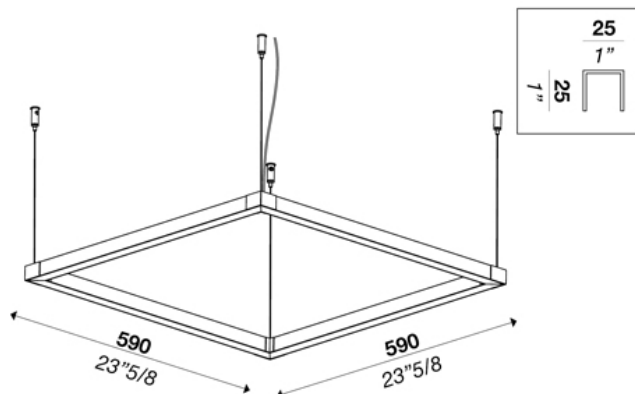
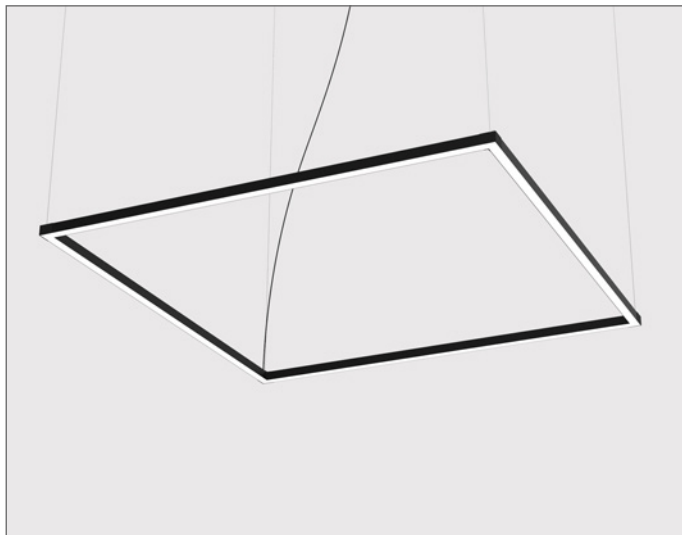

Lighting modular system with direct light. Aluminum structure in matt white, embossed black or gold finish. Linear profiles with opal polycarbonate, and round structures with opal polycarbonate diffuser. Strip LED on polycarbonate diffuser.

Power input: 48W

Light emission direction: Direct

Hanging cables:

Stainless steel cables standard length 2000 mm (78"3/4),
Electric cable standard length 2500 mm (100")

Materials: Aluminum structure, opal polycarbonate diffuser

Electrical: High efficiency electronic power supply, rated 50,000 hours 120V-277V

Dimming: Power supply compatible with 0-10V

Structure finish: Matt white, embossed black, gold



Light source: LED

3000K: 90CRI

4000K: 90CRI

Degree of protection: IP20

Source lumens: 8160 lm

Delivered lumens: 5090 lm

Source efficacy: 170 lm/W

SPECIFICATION SHEET

ORDERING INFO

Model (Order Code)	Structure Finish	LED	Driver Options
<input type="radio"/> L032650359B10100	<input type="radio"/> Matt White <input type="radio"/> Embossed Black <input type="radio"/> Gold	<input type="radio"/> 3000K <input type="radio"/> 4000K	<input type="radio"/> 120V 0-10V Dimming <input type="radio"/> 277V 0-10V Dimming



Luminart®

WWW.LUMINARTLIGHTING.COM

DAYTONA™ SQUARE 600

SUSPENSION - DARKLIGHT DIFFUSER

TYPE:

PROJECT NAME:

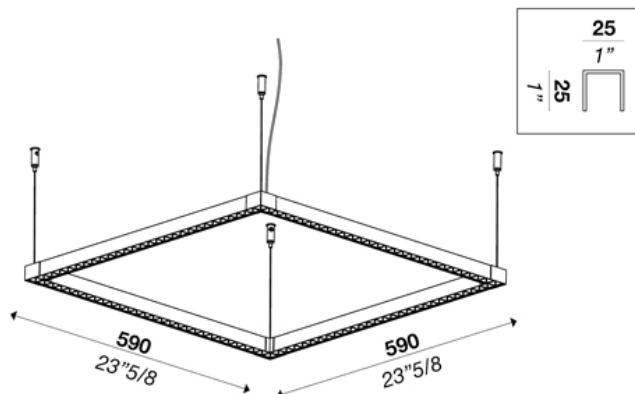
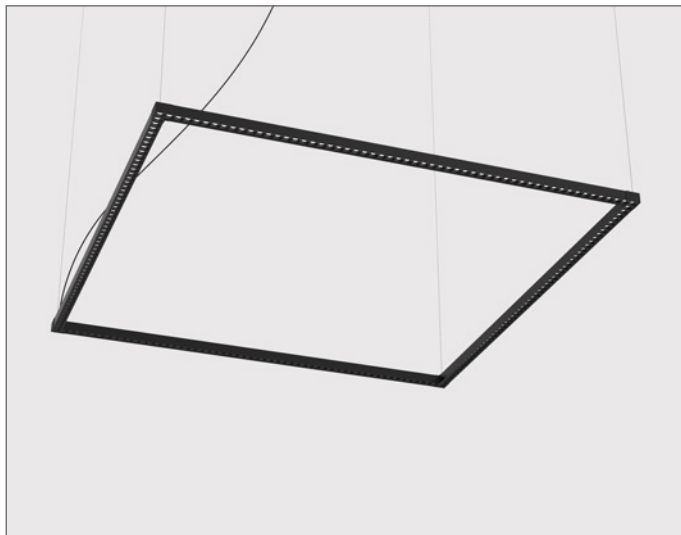

Lighting modular system with direct light. Aluminum structure in matt white, embossed black or brass finish. Linear profiles with dark light optic diffuser, and round structures with opal polycarbonate diffuser. LED module on dark light optic diffuser.

Structure finish: Matt white, embossed black, gold



Power input: 60W

Light source: LED
3000K: 90CRI
4000K: 90CRI

Light emission direction: Direct

Hanging cables:

Stainless steel cables standard length 2000 mm (78 3/4),
Electric cable standard length 2500 mm (100")

Degree of protection: IP20

Materials: Aluminum structure, PMMA dark light diffuser

Source lumens: 8700 lm

Electrical: High efficiency electronic power supply, rated
50,000 hours 120V-277V

Delivered lumens: 5574 lm

Dimming: Power supply compatible with 0-10V

Source efficacy: 145 lm/W

SPECIFICATION SHEET

ORDERING INFO

Model (Order Code)	Structure Finish	LED	Driver Options
<input type="radio"/> L032650359B10140	<input type="radio"/> Matt White <input type="radio"/> Embossed Black <input type="radio"/> Gold	<input type="radio"/> 3000K <input type="radio"/> 4000K	<input type="radio"/> 120V 0-10V Dimming <input type="radio"/> 277V 0-10V Dimming



Luminart®

WWW.LUMINARTLIGHTING.COM

DAYTONA™ SQUARE 900

SUSPENSION - OPAL DIFFUSER

TYPE:

PROJECT NAME:

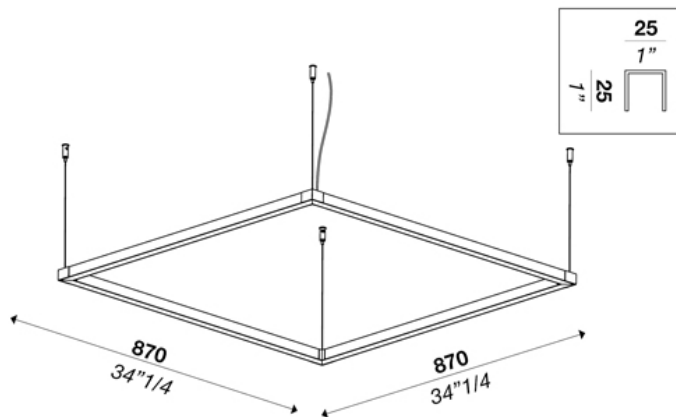
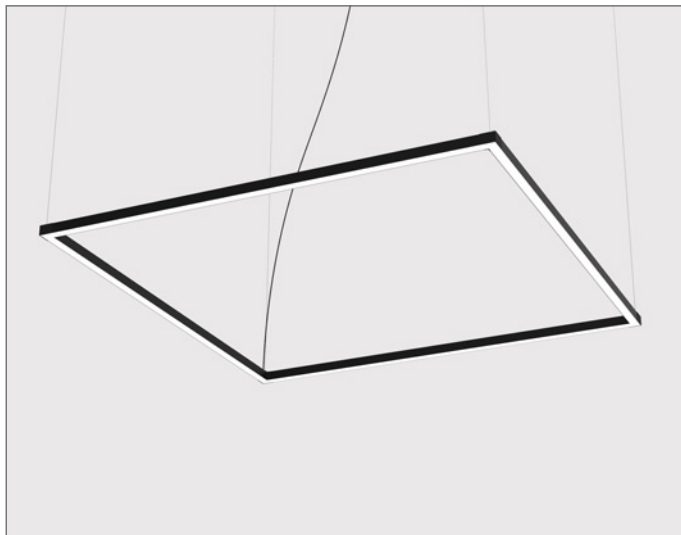

Lighting modular system with direct light. Aluminum structure in matt white, embossed black or gold finish. Linear profiles with opal polycarbonate, and round structures with opal polycarbonate diffuser. Strip LED on polycarbonate diffuser.

Power input: 72W

Light emission direction: Direct

Hanging cables:

Stainless steel cables standard length 2000 mm (78 3/4),
Electric cable standard length 2500 mm (100")

Materials: Aluminum structure, opal polycarbonate diffuser

Electrical: High efficiency electronic power supply, rated
50,000 hours 120V-277V

Dimming: Power supply compatible with 0-10V

Structure finish: Matt white, embossed black, gold

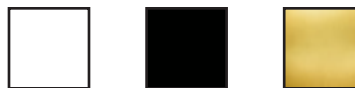

Light source: LED

3000K: 90CRI
4000K: 90CRI

Degree of protection: IP20

Source lumens: 12240 lm

Delivered lumens: 7378 lm

Source efficacy: 170 lm/W

SPECIFICATION SHEET

ORDERING INFO

Model (Order Code)	Structure Finish	LED	Driver Options
<input type="radio"/> L032650388B10100	<input type="radio"/> Matt White <input type="radio"/> Embossed Black <input type="radio"/> Gold	<input type="radio"/> 3000K <input type="radio"/> 4000K	<input type="radio"/> 120V 0-10V Dimming <input type="radio"/> 277V 0-10V Dimming



Luminart®

WWW.LUMINARTLIGHTING.COM

DAYTONA™ SQUARE 900

SUSPENSION - DARKLIGHT DIFFUSER

TYPE:

PROJECT NAME:

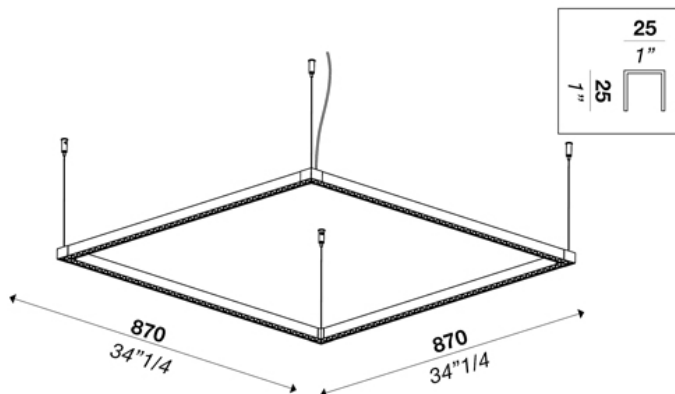
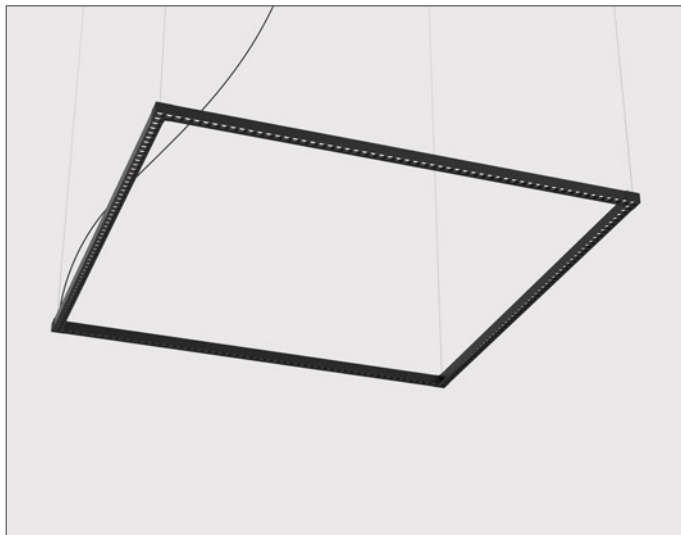

Lighting modular system with direct light. Aluminum structure in matt white, embossed black or brass finish. Linear profiles with dark light optic diffuser, and round structures with opal polycarbonate diffuser. LED module on dark light optic diffuser.

Power input: 90W

Light emission direction: Direct

Hanging cables:

Stainless steel cables standard length 2000 mm (78 3/4), Electric cable standard length 2500 mm (100")

Materials: Aluminum structure, PMMA dark light diffuser

Electrical: High efficiency electronic power supply, rated 50,000 hours 120V-277V

Dimming: Power supply compatible with 0-10V

Structure finish: Matt white, embossed black, gold



Light source: LED

3000K: 90CRI

4000K: 90CRI

Degree of protection: IP20

Source lumens: 13050 lm

Delivered lumens: 8091 lm

Source efficacy: 145 lm/W

SPECIFICATION SHEET

ORDERING INFO

Model (Order Code)	Structure Finish	LED	Driver Options
<input type="radio"/> L032650388B10140	<input type="radio"/> Matt White <input type="radio"/> Embossed Black <input type="radio"/> Gold	<input type="radio"/> 3000K <input type="radio"/> 4000K	<input type="radio"/> 120V 0-10V Dimming <input type="radio"/> 277V 0-10V Dimming



Luminart®

WWW.LUMINARTLIGHTING.COM

DAYTONA™ SQUARE 1200 TYPE:

SUSPENSION - OPAL DIFFUSER

PROJECT NAME:

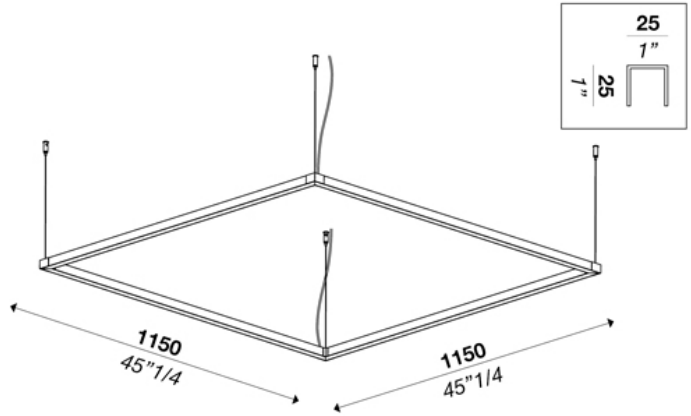
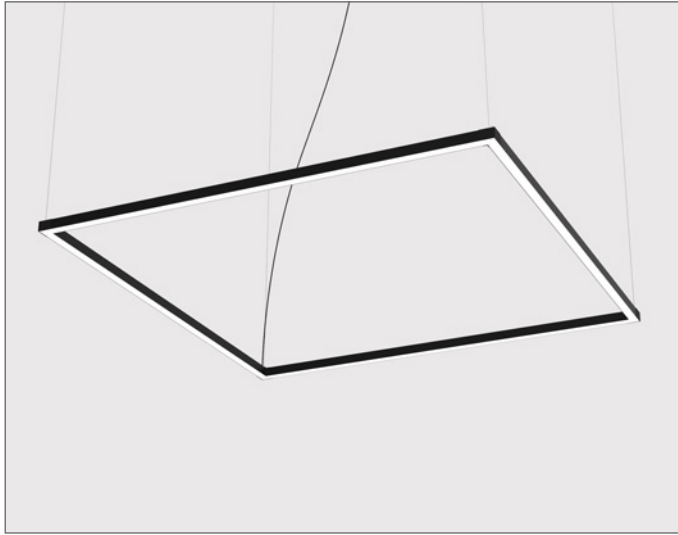

Lighting modular system with direct light. Aluminum structure in matt white, embossed black or gold finish. Linear profiles with opal polycarbonate, and round structures with opal polycarbonate diffuser. Strip LED on polycarbonate diffuser.

Power input: 96W

Light emission direction: Direct

Hanging cables:
Stainless steel cables standard length 2000 mm (78 3/4"),
Electric cable standard length 2500 mm (100")

Materials: Aluminum structure, opal polycarbonate diffuser

Electrical: High efficiency electronic power supply, rated 50,000 hours 120V-277V

Dimming: Power supply compatible with 0-10V

Structure finish: Matt white, embossed black, gold



Light source: LED
3000K: 90CRI
4000K: 90CRI

Degree of protection: IP20

Source lumens: 16320 lm

Delivered lumens: 9802 lm

Source efficacy: 170 lm/W

SPECIFICATION SHEET

ORDERING INFO

Model (Order Code)	Structure Finish	LED	Driver Options
<input type="radio"/> L032650315B10100	<input type="radio"/> Matt White <input type="radio"/> Embossed Black <input type="radio"/> Gold	<input type="radio"/> 3000K <input type="radio"/> 4000K	<input type="radio"/> 120V 0-10V Dimming <input type="radio"/> 277V 0-10V Dimming



DAYTONA™ SQUARE 1200 TYPE:

SUSPENSION - DARKLIGHT DIFFUSER

PROJECT NAME:

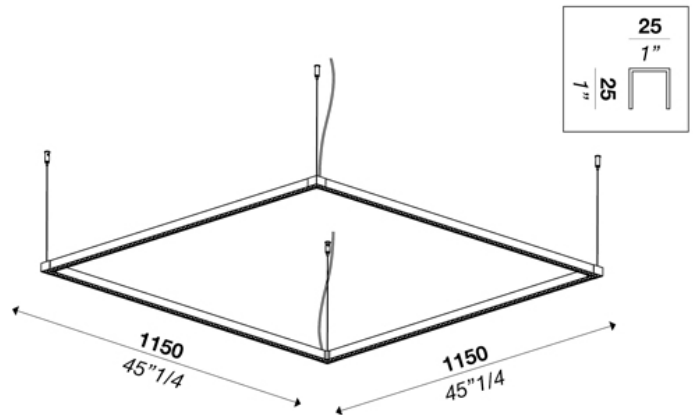
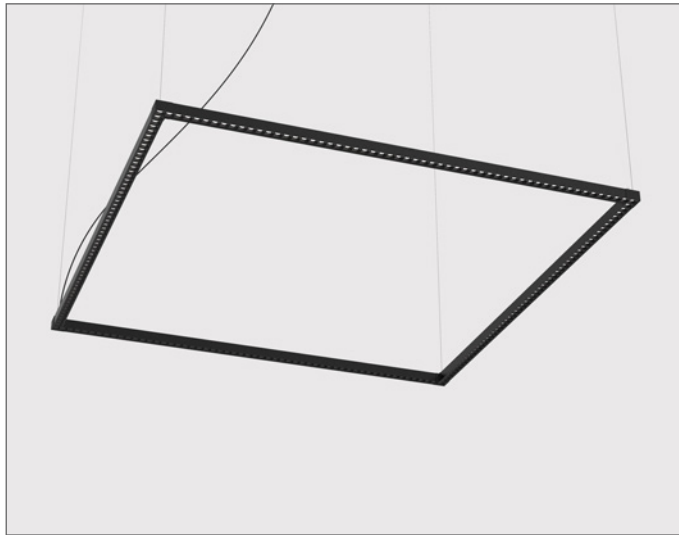

Lighting modular system with direct light. Aluminum structure in matt white, embossed black or brass finish. Linear profiles with dark light optic diffuser, and round structures with opal polycarbonate diffuser. LED module on dark light optic diffuser.

Structure finish: Matt white, embossed black, gold



Power input: 120W

Light source: LED
3000K: 90CRI
4000K: 90CRI

Light emission direction: Direct

Degree of protection: IP20

Hanging cables:

Stainless steel cables standard length 2000 mm (78 3/4),
Electric cable standard length 2500 mm (100")

Source lumens: 17400 lm

Materials: Aluminum structure, PMMA dark light diffuser

Delivered lumens: 10608 lm

Electrical: High efficiency electronic power supply, rated
50,000 hours 120V-277V

Source efficacy: 145 lm/W

Dimming: Power supply compatible with 0-10V

SPECIFICATION SHEET

ORDERING INFO

Model (Order Code)	Structure Finish	LED	Driver Options
<input type="radio"/> L032650315B10140	<input type="radio"/> Matt White <input type="radio"/> Embossed Black <input type="radio"/> Gold	<input type="radio"/> 3000K <input type="radio"/> 4000K	<input type="radio"/> 120V 0-10V Dimming <input type="radio"/> 277V 0-10V Dimming



DAYTONA™ SQUARE 1400 TYPE:

SUSPENSION - OPAL DIFFUSER

PROJECT NAME:

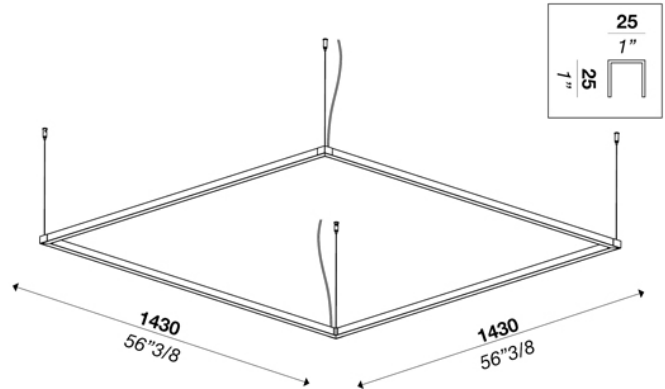
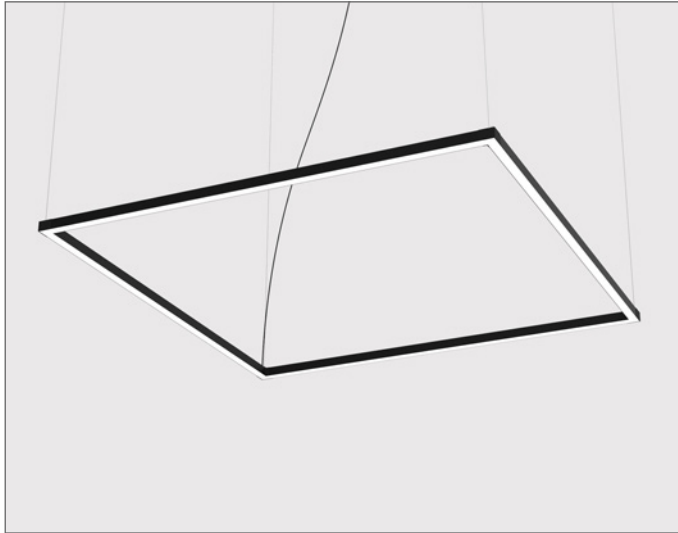

Lighting modular system with direct light. Aluminum structure in matt white, embossed black or gold finish. Linear profiles with opal polycarbonate, and round structures with opal polycarbonate diffuser. Strip LED on polycarbonate diffuser.

Power input: 112W

Light emission direction: Direct

Hanging cables:
Stainless steel cables standard length 2000 mm (78 3/4),
Electric cable standard length 2500 mm (100")

Materials: Aluminum structure, opal polycarbonate diffuser

Electrical: High efficiency electronic power supply, rated 50,000 hours 120V-277V

Dimming: Power supply compatible with 0-10V

Structure finish: Matt white, embossed black, gold



Light source: LED
3000K: 90CRI
4000K: 90CRI

Degree of protection: IP20

Source lumens: 19040 lm

Delivered lumens: 12121 lm

Source efficacy: 170 lm/W

SPECIFICATION SHEET

ORDERING INFO

Model (Order Code)	Structure Finish	LED	Driver Options
<input type="radio"/> L032650316B10100	<input type="radio"/> Matt White <input type="radio"/> Embossed Black <input type="radio"/> Gold	<input type="radio"/> 3000K <input type="radio"/> 4000K	<input type="radio"/> 120V 0-10V Dimming <input type="radio"/> 277V 0-10V Dimming



DAYTONA™ SQUARE 1400 TYPE:

SUSPENSION - DARKLIGHT DIFFUSER

PROJECT NAME:

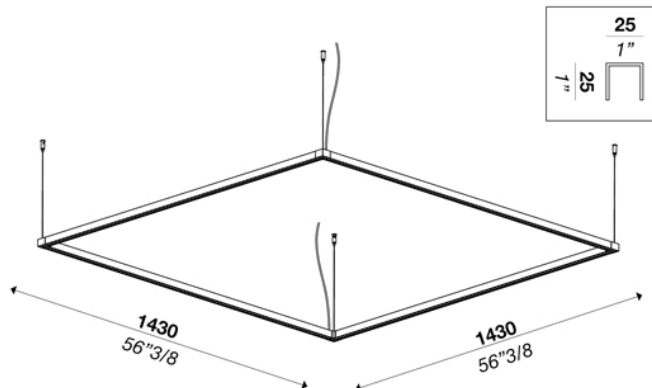
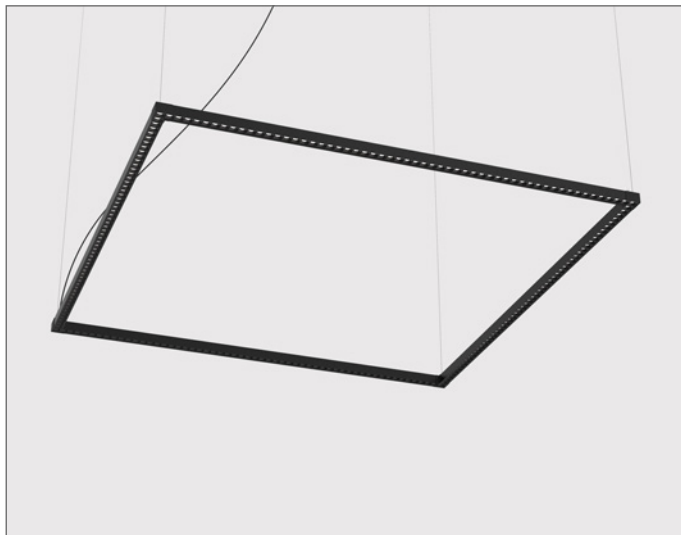

Lighting modular system with direct light. Aluminum structure in matt white, embossed black or brass finish. Linear profiles with dark light optic diffuser, and round structures with opal polycarbonate diffuser. LED module on dark light optic diffuser.

Structure finish: Matt white, embossed black, gold

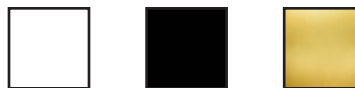

Power input: 150W

Light source: LED
3000K: 90CRI
4000K: 90CRI

Light emission direction: Direct

Hanging cables:

Stainless steel cables standard length 2000 mm (78 3/4),
Electric cable standard length 2500 mm (100")

Degree of protection: IP20

Materials: Aluminum structure, PMMA dark light diffuser

Source lumens: 21750 lm

Electrical: High efficiency electronic power supply, rated
50,000 hours 120V-277V

Delivered lumens: 13305 lm

Dimming: Power supply compatible with 0-10V

Source efficacy: 145 lm/W

SPECIFICATION SHEET

ORDERING INFO

Model (Order Code)	Structure Finish	LED	Driver Options
<input type="radio"/> L032650316B10140	<input type="radio"/> Matt White <input type="radio"/> Embossed Black <input type="radio"/> Gold	<input type="radio"/> 3000K <input type="radio"/> 4000K	<input type="radio"/> 120V 0-10V Dimming <input type="radio"/> 277V 0-10V Dimming



DAYTONA™ SQUARE 1700 TYPE:

SUSPENSION - OPAL DIFFUSER

PROJECT NAME:

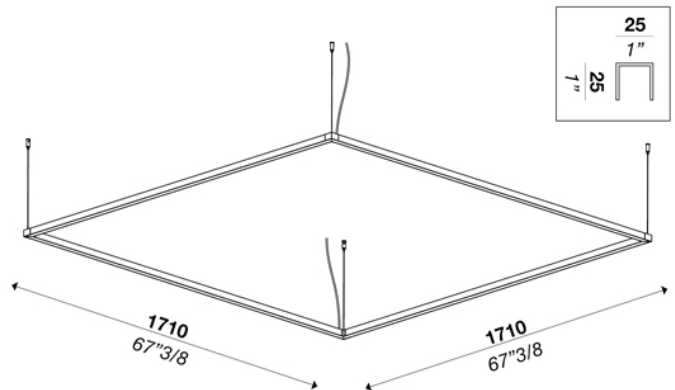
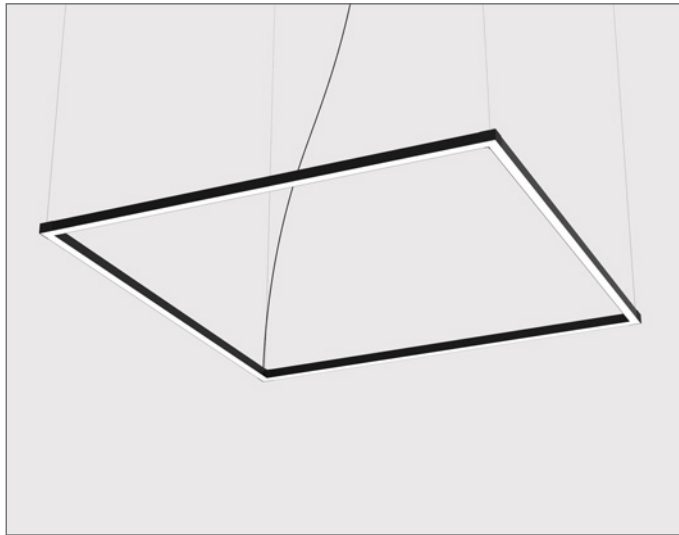

Lighting modular system with direct light. Aluminum structure in matt white, embossed black or gold finish. Linear profiles with opal polycarbonate, and round structures with opal polycarbonate diffuser. Strip LED on polycarbonate diffuser.

Power input: 136W

Light emission direction: Direct

Hanging cables:
Stainless steel cables standard length 2000 mm (78 3/4),
Electric cable standard length 2500 mm (100")

Materials: Aluminum structure, opal polycarbonate diffuser

Electrical: High efficiency electronic power supply, rated 50,000 hours 120V-277V

Dimming: Power supply compatible with 0-10V

Structure finish: Matt white, embossed black, gold



Light source: LED
3000K: 90CRI
4000K: 90CRI

Degree of protection: IP20

Source lumens: 23120 lm

Delivered lumens: 14440 lm

Source efficacy: 170 lm/W

SPECIFICATION SHEET

ORDERING INFO

Model (Order Code)	Structure Finish	LED	Driver Options
<input type="radio"/> L032650319B10100	<input type="radio"/> Matt White <input type="radio"/> Embossed Black <input type="radio"/> Gold	<input type="radio"/> 3000K <input type="radio"/> 4000K	<input type="radio"/> 120V 0-10V Dimming <input type="radio"/> 277V 0-10V Dimming



Luminart®

WWW.LUMINARTLIGHTING.COM

DAYTONA™ SQUARE 1700 TYPE:

SUSPENSION - DARKLIGHT DIFFUSER

PROJECT NAME:

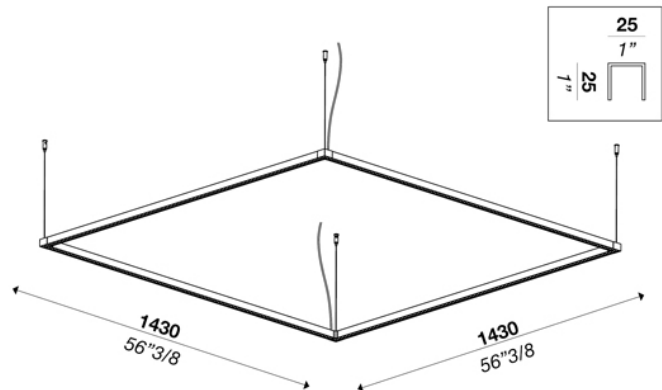
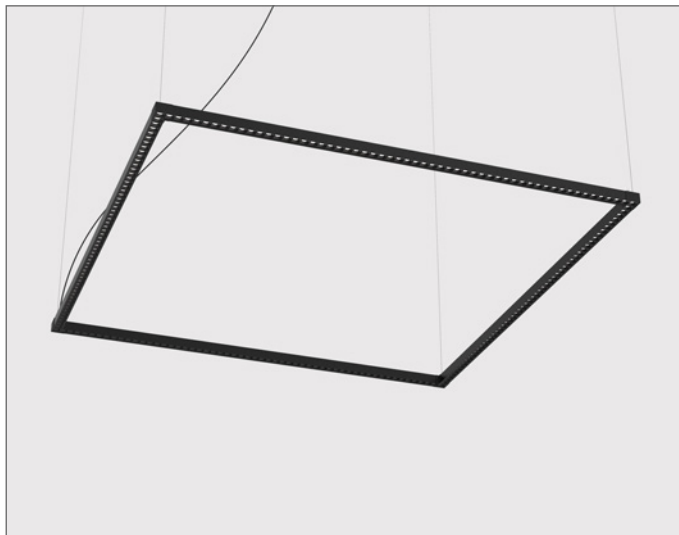

Lighting modular system with direct light. Aluminum structure in matt white, embossed black or brass finish. Linear profiles with dark light optic diffuser, and round structures with opal polycarbonate diffuser. LED module on dark light optic diffuser.

Structure finish: Matt white, embossed black, gold



Power input: 180W

Light source: LED
3000K: 90CRI
4000K: 90CRI

Light emission direction: Direct

Hanging cables:

Stainless steel cables standard length 2000 mm (78 3/4),
Electric cable standard length 2500 mm (100")

Degree of protection: IP20

Materials: Aluminum structure, PMMA dark light diffuser

Source lumens: 26100 lm

Electrical: High efficiency electronic power supply, rated
50,000 hours 120V-277V

Delivered lumens: 15822 lm

Dimming: Power supply compatible with 0-10V

Source efficacy: 145 lm/W

SPECIFICATION SHEET

ORDERING INFO

Model (Order Code)	Structure Finish	LED	Driver Options
<input type="radio"/> L032650319B10140	<input type="radio"/> Matt White <input type="radio"/> Embossed Black <input type="radio"/> Gold	<input type="radio"/> 3000K <input type="radio"/> 4000K	<input type="radio"/> 120V 0-10V Dimming <input type="radio"/> 277V 0-10V Dimming



Luminart®

WWW.LUMINARTLIGHTING.COM