

POP™ 04 MAGIC

INSTALLATION INSTRUCTIONS

TYPE:

PROJECT NAME:

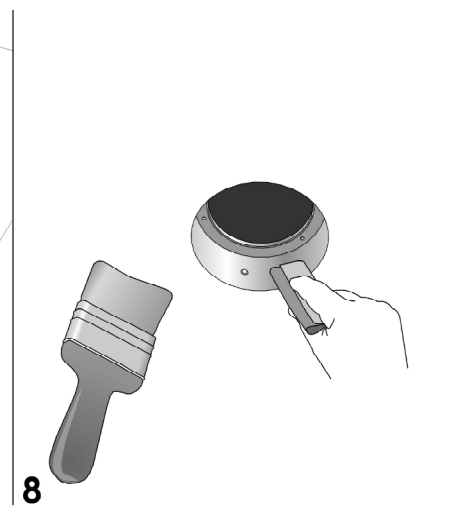
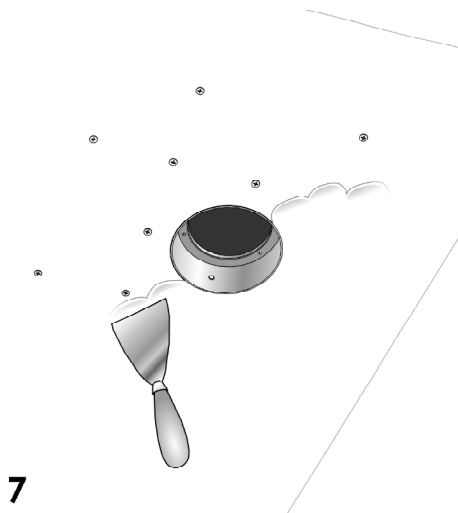
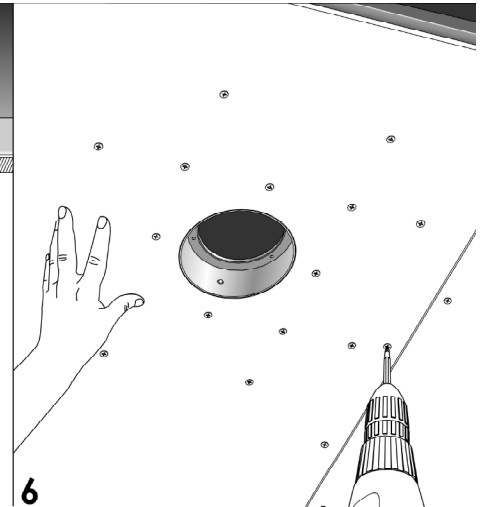
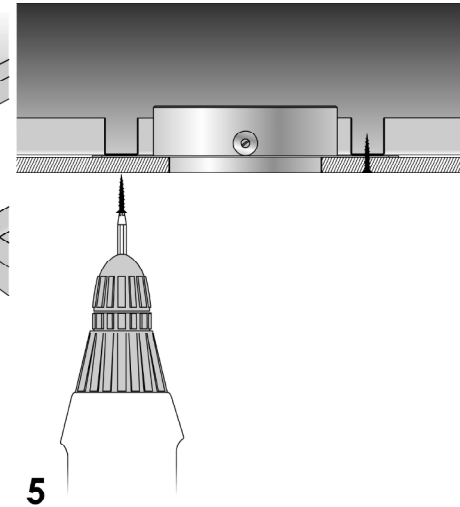
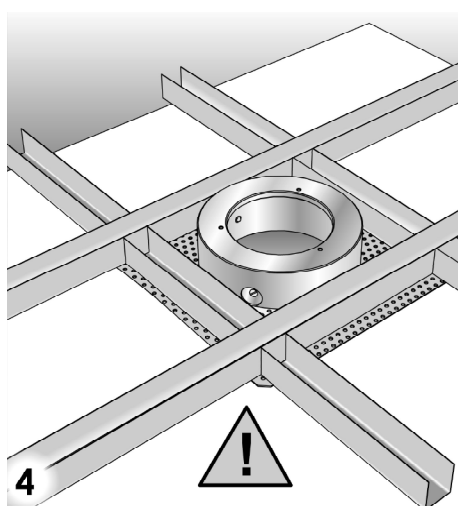
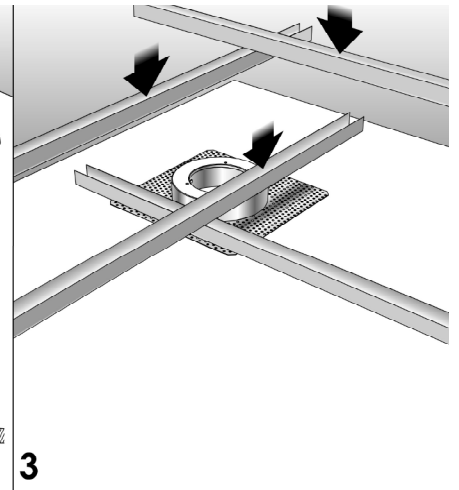
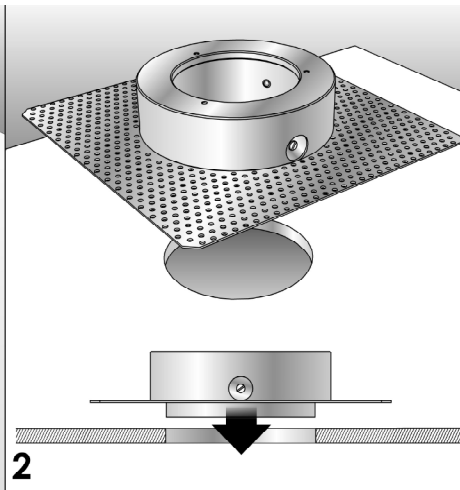
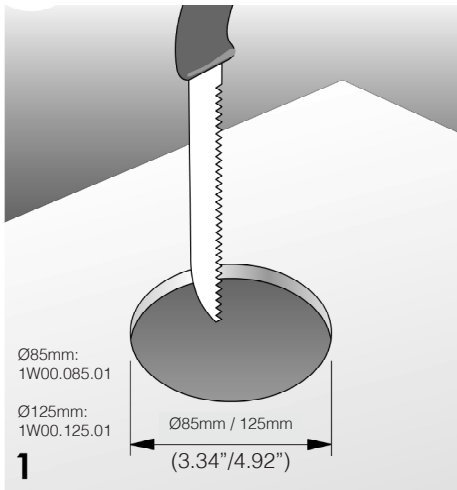

- 1) Once pointed the position of the lamp, cut the hole for the housing.
- 2) Place the housing on the side of the plasterboard plate that will remain invisible after the work is done.
- 3-4) Put some metal profiles to fix and reinforce the area of the housing.
- 5) Fix with screws, the housing to the plasterboard and to the reinforcement profiles.
- 6-7) Complete the false ceiling, plaster and trim.
- 8) Keep clean the inside of the housing.

POP™ 04 MAGIC

INSTALLATION INSTRUCTIONS

TYPE:

PROJECT NAME:

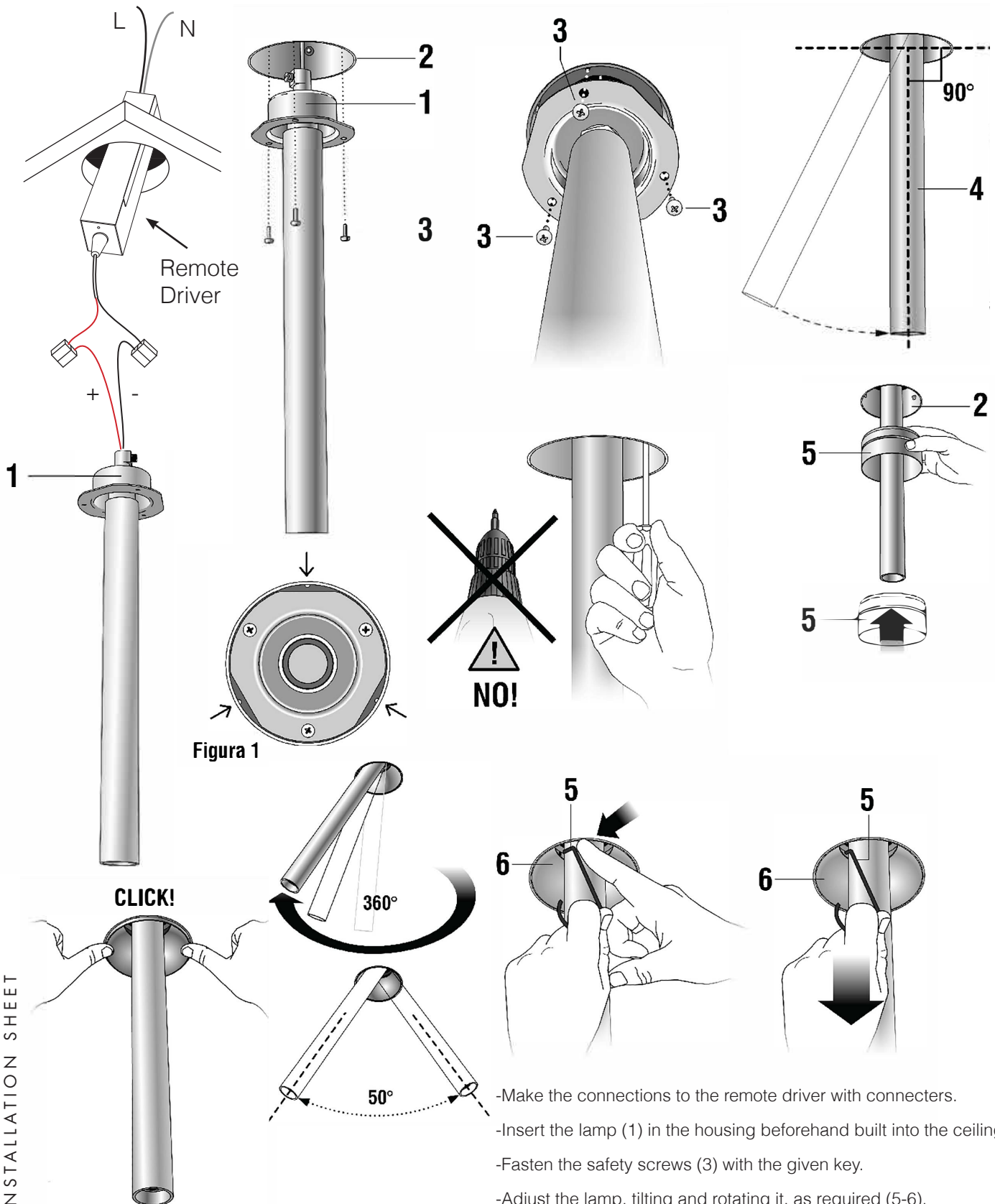

Figura 1

- Make the connections to the remote driver with connectors.
- Insert the lamp (1) in the housing beforehand built into the ceiling (2).
- Fasten the safety screws (3) with the given key.
- Adjust the lamp, tilting and rotating it, as required (5-6).

INSTALLATION SHEET