

# SELTZER™

## INSTALLATION INSTRUCTIONS

TYPE:

PROJECT NAME:

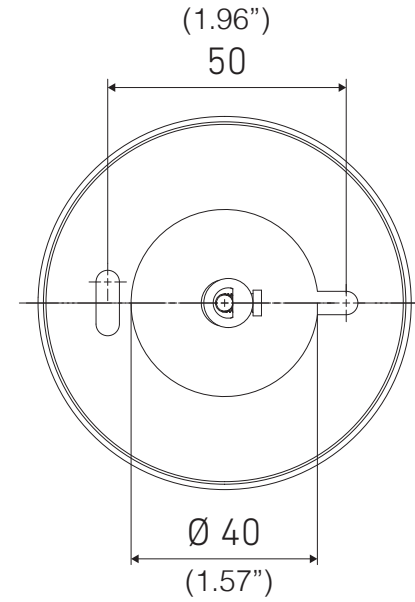
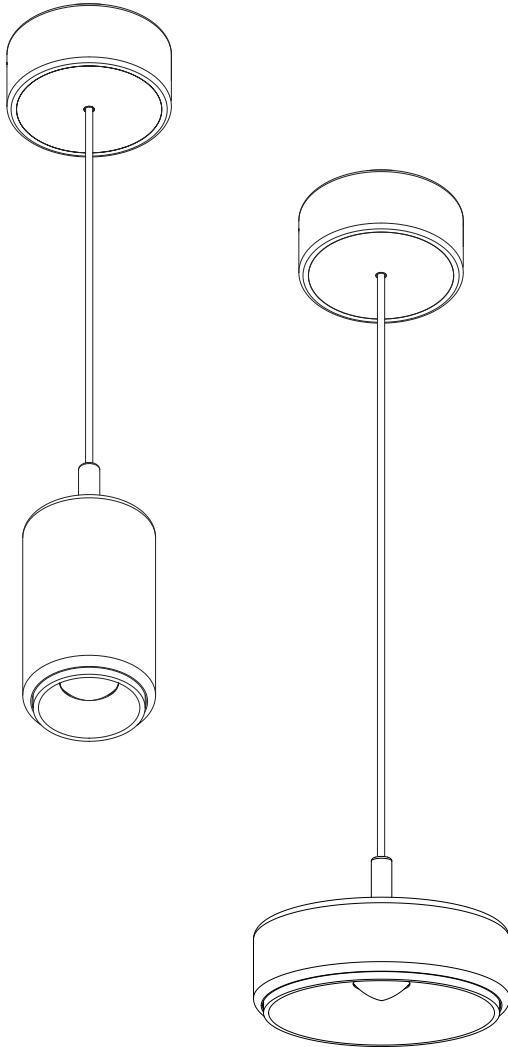

### ELECTRICAL WIRING DIAGRAMS

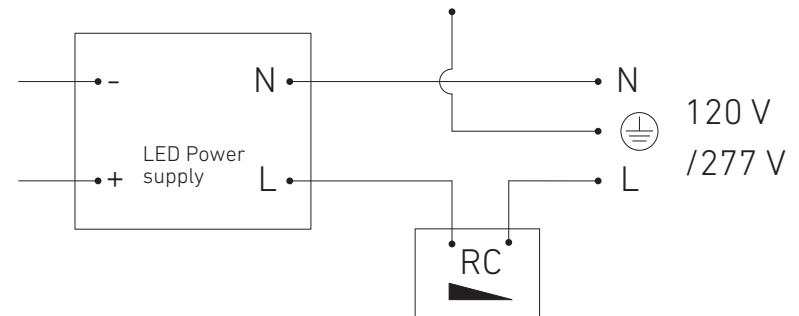

1. Turn off the power.
2. Attach the mounting bracket to the mounting crossbar with screws (A) and mount the crossbar to the junction box.
3. Adjust the length of the wire and lock it with the end stop. You can store the excess in the box or cut off the lamp.
4. Connect the 120-277V power to the driver. Remember to ground (electrical wiring diagrams on the first page).
5. Use the blocks to screw the base to the mounting bracket.
6. Turn on the power.

Note: The enclosed tool kit is designed for solid materials (solid brick, wood, concrete, aerated concrete) and gypsum board surfaces. The dowel should be properly matched to the mounting surface. Proper use of the dowel affects the safety and strength of the structure.

