

TOAD™

SUSPENSION

TYPE:

PROJECT NAME:



SPECIFICATION SHEET

Luminart®

WWW.LUMINARTLIGHTING.COM
Last updated: 07/10/24

TOAD™ S750

SUSPENSION

TYPE:

PROJECT NAME:



Measurements:

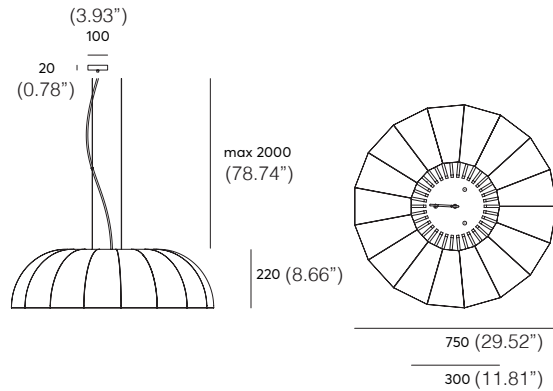

Material:

PET Felt (polyethylene terephthalate)

Fixture:

2m (78.74") black textile cable
 3 black metal wires with adjustable griplock
 Black ceiling cap

Acoustic properties:



1,98 m² of acoustic absorption material of aw 0,45

Total weight gross | net:

5,5 | 4,3kg

SPECIFICATION SHEET

ORDERING INFO

TOAD S750

Model (Order Code)	Inside Acoustic Options	Outside Acoustic Options	LED	Dimming Options
<input type="radio"/> TOAD S750	<input type="radio"/> See Acoustic Finish Options on Next Page	<input type="radio"/> See Acoustic Finish Options on Next Page	<input type="radio"/> 27: 2700K <input type="radio"/> 30: 3000K <input type="radio"/> 40: 4000K	<input type="radio"/> 120V LTE <input type="radio"/> 120-277V 0-10V (Universal Voltage)



TOAD™ S750

SUSPENSION

TYPE:

PROJECT NAME:

Inside Finish:

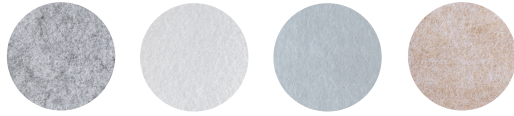

11_Fog Grey 07_Ghost White 30_Cool Grey 04_Bisque

Outside Finish:



13_Black 03_Charcoal 36_Dim Grey 11_Fog Grey 07_Ghost White 19_Midnight 26_Ocean 30_Cool Grey 41_Mint Pastel



17_Forest 40_Faded Jade 06_Olive 39_Warm Grey 04_Bisque 35_Ochre 45_Chilli 09_Lavender 31_Rosé

Light source specifications:



LED power: 17W
 Luminous Flux: 1850lm
 Frequency: 47-63Hz
 Power factor: 109lm/W
 Optics | Beam of light: Acrylic Opal Prism | 85°
 CRI: Ra >80
 UGR: <22
 Operating temperature: -20 ~ +45

Photometrics:

Lumen intensity distribution

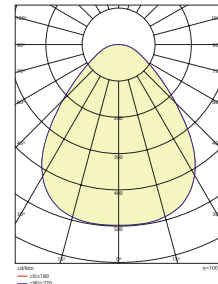

Acoustic specifications:

The acoustic design principle.

Toad is designed to catch sound directly from the space where sound is created. Such as meeting rooms or dining tables.

Because of its large open design, soundwaves will travel inside the shade and the mushroom like slats absorb the sound.

The LED element, will reflect the soundwaves

Calculated acoustic surface area: 1,98 m²

aw (ISO 11654) = 0,45

SAA (ASTM - C423) = 0,45

Measurement of 9mm free hanging PET Felt

sound absorption calculation in a reverberation room

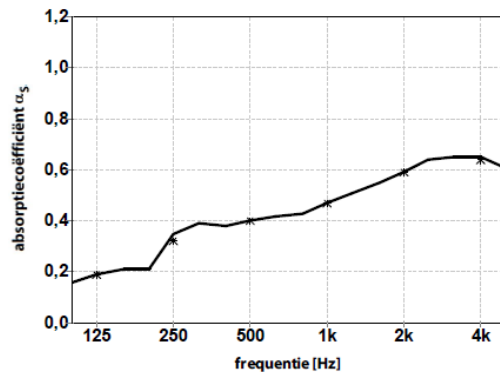

	0,16	0,21	0,38	0,43	0,55	0,65
1/3 oct.	0,19	0,35	0,40	0,47	0,59	0,65
	0,21	0,39	0,42	0,51	0,64	0,61
1/1 oct.	0,19	0,32	0,40	0,47	0,59	0,64

TOAD™ M1000

SUSPENSION

TYPE:

PROJECT NAME:



Measurements:

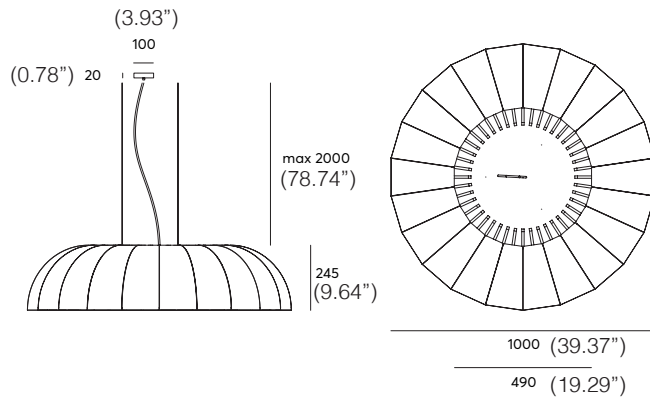

Material:

PET Felt (polyethylene terephthalate)

Fixture:

2m (78.74") black textile cable
 3 black metal wires with adjustable griplock
 Black ceiling cap

Acoustic properties:



3,27 m² of acoustic absorption material of aw 0,45

Total weight gross | net:

10,6 | 9,4kg

SPECIFICATION SHEET

ORDERING INFO

TOAD M1000

Model (Order Code)	Inside Acoustic Options	Outside Acoustic Options	LED	Dimming Options
<input type="radio"/> TOAD M1000	<input type="radio"/> See Acoustic Finish Options on Next Page	<input type="radio"/> See Acoustic Finish Options on Next Page	<input type="radio"/> 27: 2700K <input type="radio"/> 30: 3000K <input type="radio"/> 40: 4000K	<input type="radio"/> 120V LTE <input type="radio"/> 120-277V 0-10V (Universal Voltage)



TOAD™ M1000

SUSPENSION

TYPE:

PROJECT NAME:

Inside Colors:



Colors:



Light source specifications:



LED power: 36W
 Luminous Flux: 3560lm
 Frequency: 47-63Hz
 Power factor: 99lm/W
 Optics | Beam of light: Acrylic Opal Prism | 85°
 CRI: Ra >80
 UGR: <22
 Operating temperature: -20 ~ +45

Photometrics:

Lumen intensity distribution

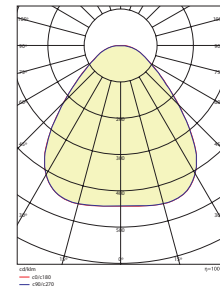

Acoustic specifications:

The acoustic design principle.

Toad is designed to catch sound directly from the space where sound is created. Such as meeting rooms or dining tables.

Because of its large open design, soundwaves will travel inside the shade and the mushroom like slats absorb the sound.

The LED element, will reflect the soundwaves

Calculated acoustic surface area: 3,27 m²

aw (ISO 11654) = 0,45

SAA (ASTM - C423) = 0,45

Measurement of 9mm free hanging PET Felt sound absorption calculation in a reverberation room

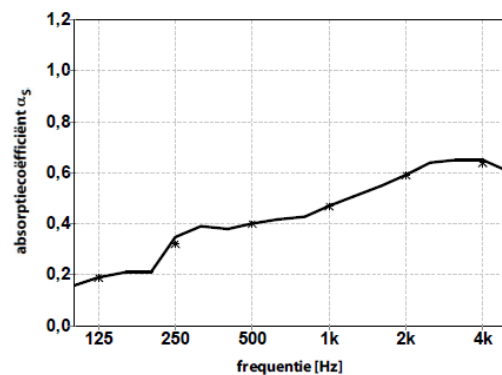

	0,16	0,21	0,38	0,43	0,55	0,65
1/3 oct.	0,19	0,35	0,40	0,47	0,59	0,65
	0,21	0,39	0,42	0,51	0,64	0,61
1/1 oct.	0,19	0,32	0,40	0,47	0,59	0,64

TOAD™ L1500

SUSPENSION

TYPE:

PROJECT NAME:



Measurements:

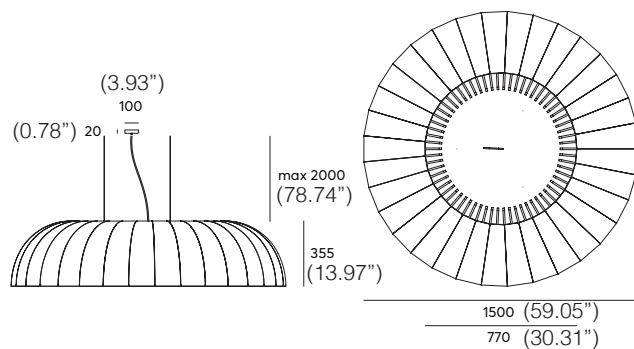

Material:

PET Felt (polyethylene terephthalate)

Fixture:

2m (78.74") black textile cable
4 black metal wires with adjustable griplock
Black ceiling cap

Acoustic properties:



8,84 m² of acoustic absorption material of aw 0,45

Total weight gross | net:

28,9 | 25,7kg

SPECIFICATION SHEET

ORDERING INFO

TOAD L1500

Model (Order Code)	Inside Acoustic Options	Outside Acoustic Options	LED	Dimming Options
<input type="radio"/> TOAD L1500	<input type="radio"/> See Acoustic Finish Options on Next Page	<input type="radio"/> See Acoustic Finish Options on Next Page	<input type="radio"/> 30: 3000K <input type="radio"/> 40: 4000K	<input type="radio"/> 120V LTE <input type="radio"/> 120-277V 0-10V (Universal Voltage)



TOAD™ L1500

SUSPENSION

TYPE:

PROJECT NAME:

Inside Colors:

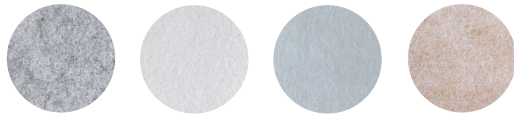

11_Fog Grey 07_Ghost White 30_Cool Grey 04_Bisque

Colors:



13_Black 03_Charcoal 36_Dim Grey 11_Fog Grey 07_Ghost White 19_Midnight 26_Ocean 30_Cool Grey 41_Mint Pastel



17_Forest 40_Faded Jade 06_Olive 39_Warm Grey 04_Bisque 35_Ochre 45_Chilli 09_Lavender 31_Rosé

Light source specifications:



LED power: 64W
 Luminous Flux: 6870lm
 Frequency: 50/60Hz
 Power factor: 107lm/W
 Optics | Beam of light: Acrylic Opal Prism | 83°
 CRI: Ra>80
 UGR: <19
 Operating temperature: -20 ~ +45

Photometrics:

Lumen intensity distribution

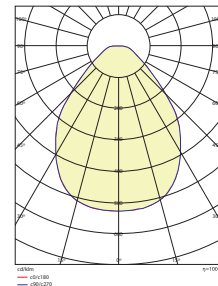

Acoustic specifications:

The acoustic design principle.

Toad is designed to catch sound directly from the space where sound is created. Such as meeting rooms or dining tables.

Because of its large open design, soundwaves will travel inside the shade and the mushroom like slats absorb the sound.

The LED element, will reflect the soundwaves

Calculated acoustic surface area: 8,84 m²

aw (ISO 11654) = 0,45

SAA (ASTM - C423) = 0,45

Measurement of 9mm free hanging PET Felt

sound absorption calculation in a reverberation room

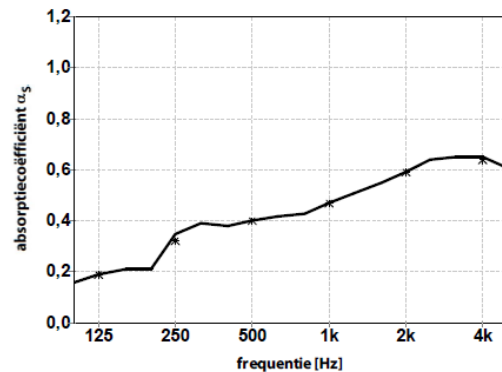

	0,16	0,21	0,38	0,43	0,55	0,65
1/3 oct.	0,19	0,35	0,40	0,47	0,59	0,65
	0,21	0,39	0,42	0,51	0,64	0,61
1/1 oct.	0,19	0,32	0,40	0,47	0,59	0,64

SPECIFICATION SHEET