

# T-LUX™ OLLIE

INSTALLATION INSTRUCTIONS

TYPE:

PAGE: 1 of 4

PROJECT NAME:



L985553

L985553

+

- L983601 h.200
- L983602 h.400
- L983603 h.700



L985538

INSTALLATION SHEET

### **BEFORE YOU START**

The luminaire is designed for installation on pole (L983601, L983602, L983603). These instructions are also valid for the above codes.

We recommend the use of the accessory:

Plate with Anchoring set L985538 Make sure the pole has adequate drainage inside. The orientation of the pole base, indicated by the arrow, determines the position of the lateral fixing screws. Pay attention to the positions of the arrows in the diagram on the side.

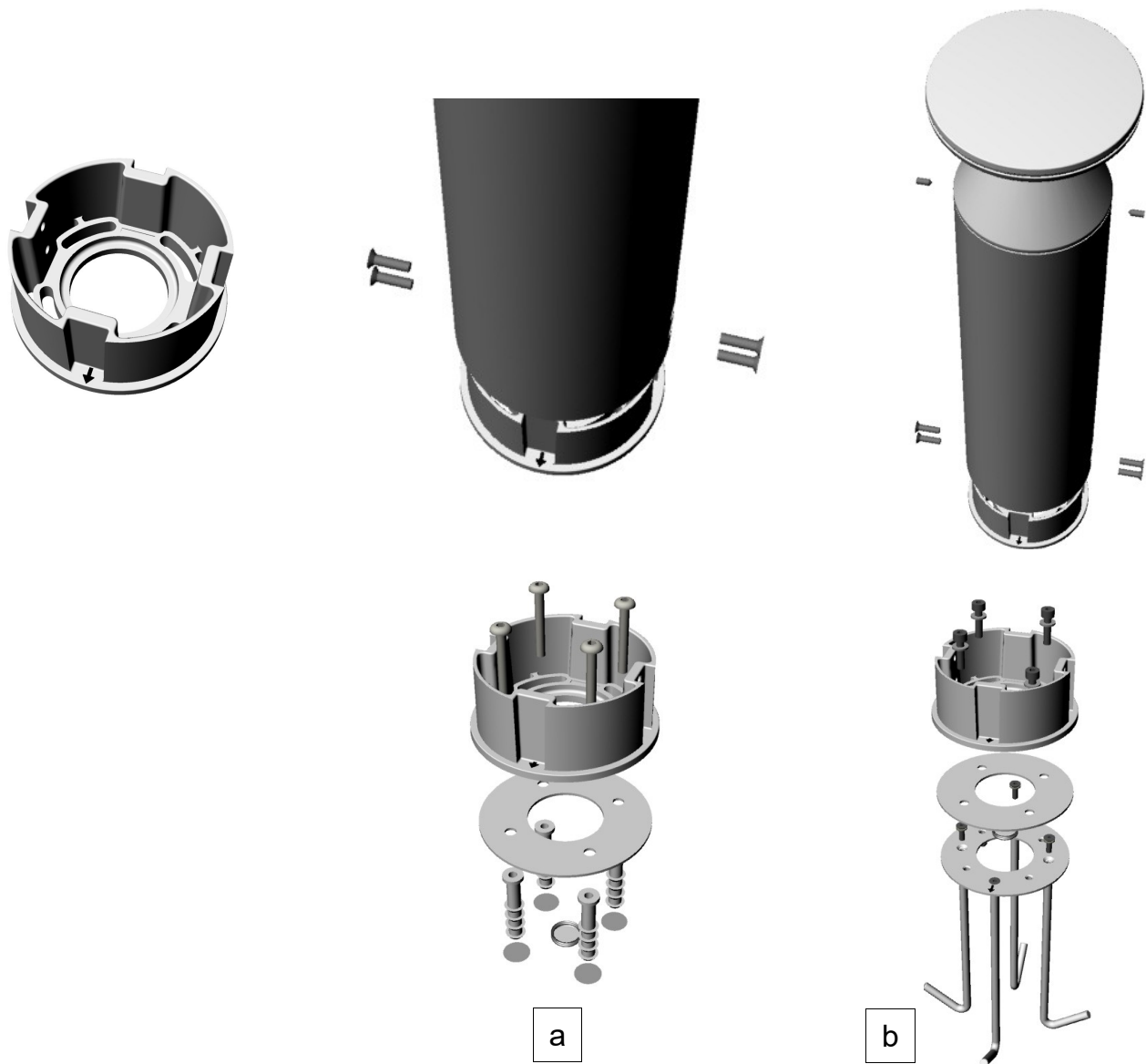

### **INSTALLATION**

Fix the base of the pole to the ground by means of:

a- Fischer

b- Plate with ground anchoring set L985538 – Use the allen screws supplied with the accessory. Always use the supplied insulating rubber.

Make the connections to the power cables. Insert the luminaire inside the pole and lock it with the respective grub screws. Insert the pole onto its base and secure it with the respective screws in the indicated sequence. (I – II – III – IV) Lubricate the screws.

**Attention:** Tighten the screws and the grub screws just until they stop. Do not force further.

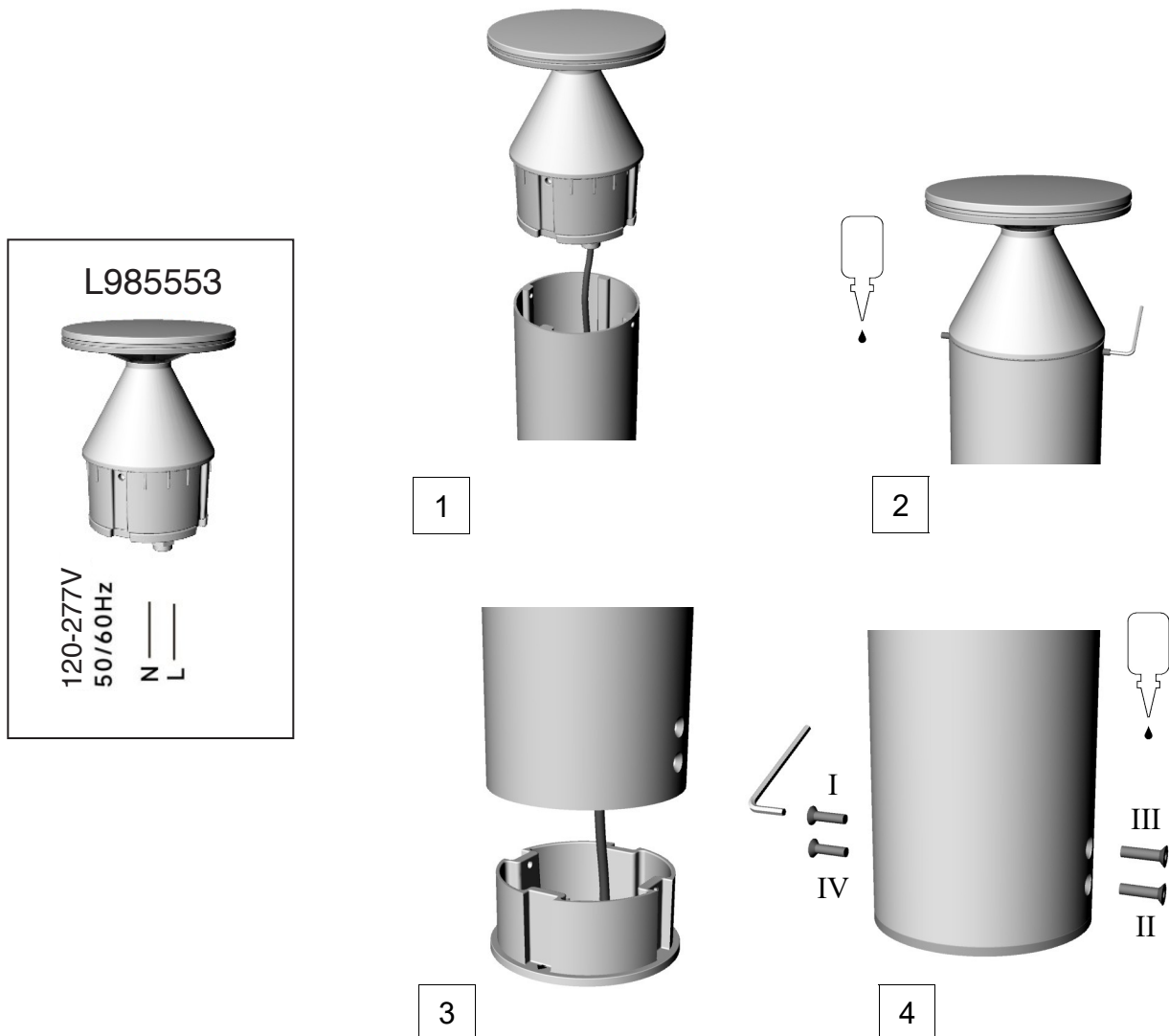

### **WARNINGS**

The installation and maintenance operations must be executed with the power supply removed, by qualified operators in compliance with the national safety rules.

Clean the appliance regularly but avoiding the use of pressure cleaners, abrasive brushes or sponges that can scratch the surface paint layer. For the same reason avoid using solvent-based detergents in favour of a soft cloth and a neutral pH detergent.

Using the device in a saline environment with high humidity requires at least a monthly cleaning.

Regularly check the integrity of the connection cables, gaskets and the appliance in general and in case of replacements use only original spare parts.

If the installation site is especially subjected to overvoltage events, we recommend the use of additional overvoltage protections (Surge Protection Device).

The IP rating of the electrical connections must be equal to or higher than the device IP rating.

Do not install or open the appliance in rainy, foggy or high humidity conditions.

The light source contained in this luminaire must only be replaced by the manufacturer or its assistance service or by equally qualified personnel.

If the external flexible cable of the device is damaged, it must be replaced either by the manufacturer or its after-sales service, or by equally qualified personnel.

Avoid causing damage to the paint during the installation or the maintenance due to the onset of corrosive phenomena. For the same reason, do not use tools near the lamp such as lawn mowers or brush cutters.

To prevent corrosive phenomena, avoid that metal parts come into contact with the ground and / or are exposed to products such as fertilizers, pesticides, solvents, salt, etc.

Keep the instructions.