

OFFSET™

INSTALLATION INSTRUCTIONS

TYPE:

PROJECT NAME:

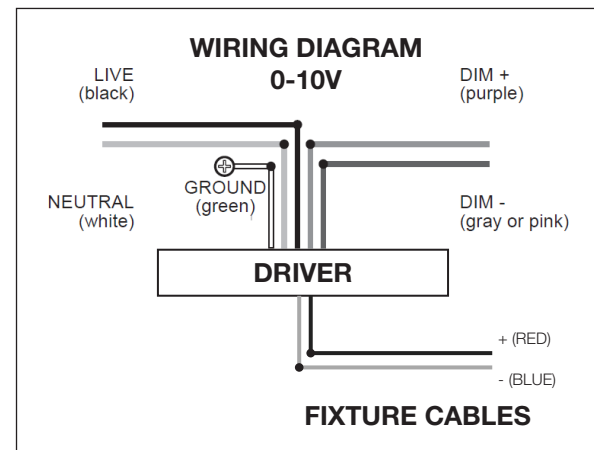
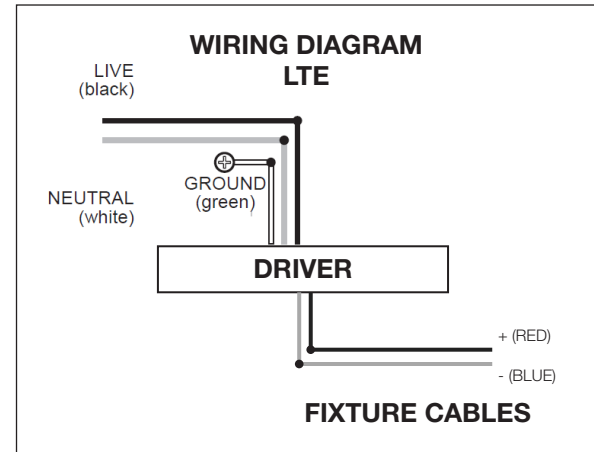
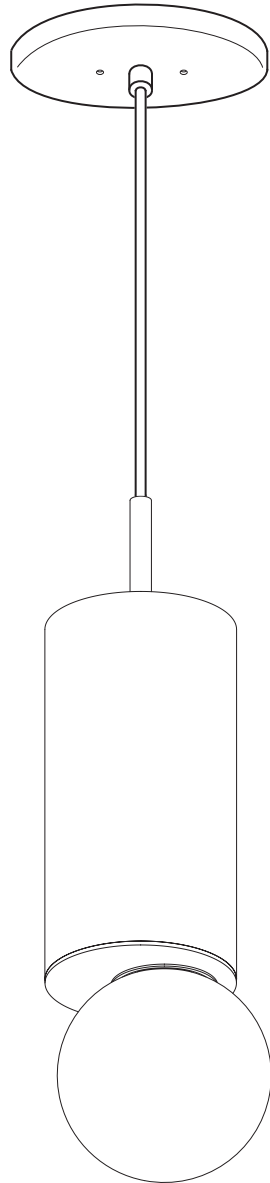

INSTALLATION SHEET

OFFSET™

INSTALLATION INSTRUCTIONS

TYPE:

PROJECT NAME:

1. Turn off the power.
2. Make the wiring connections between the fixture and driver. Connect the 120-277V power to the driver. Remember to ground (electrical wiring diagrams on the first page).
3. Adjust the length of the wire and lock it with the wire end stop (A).
4. Mount the crossbar to the junction box and attach the plate to the mounting crossbar with screws.
5. Screw the casing onto the mounting bracket.
6. Attach the lampshade to the housing gently by turning it to the first stop.
7. Turn on the power.

