

INSTALLATION FOR CONCRETE

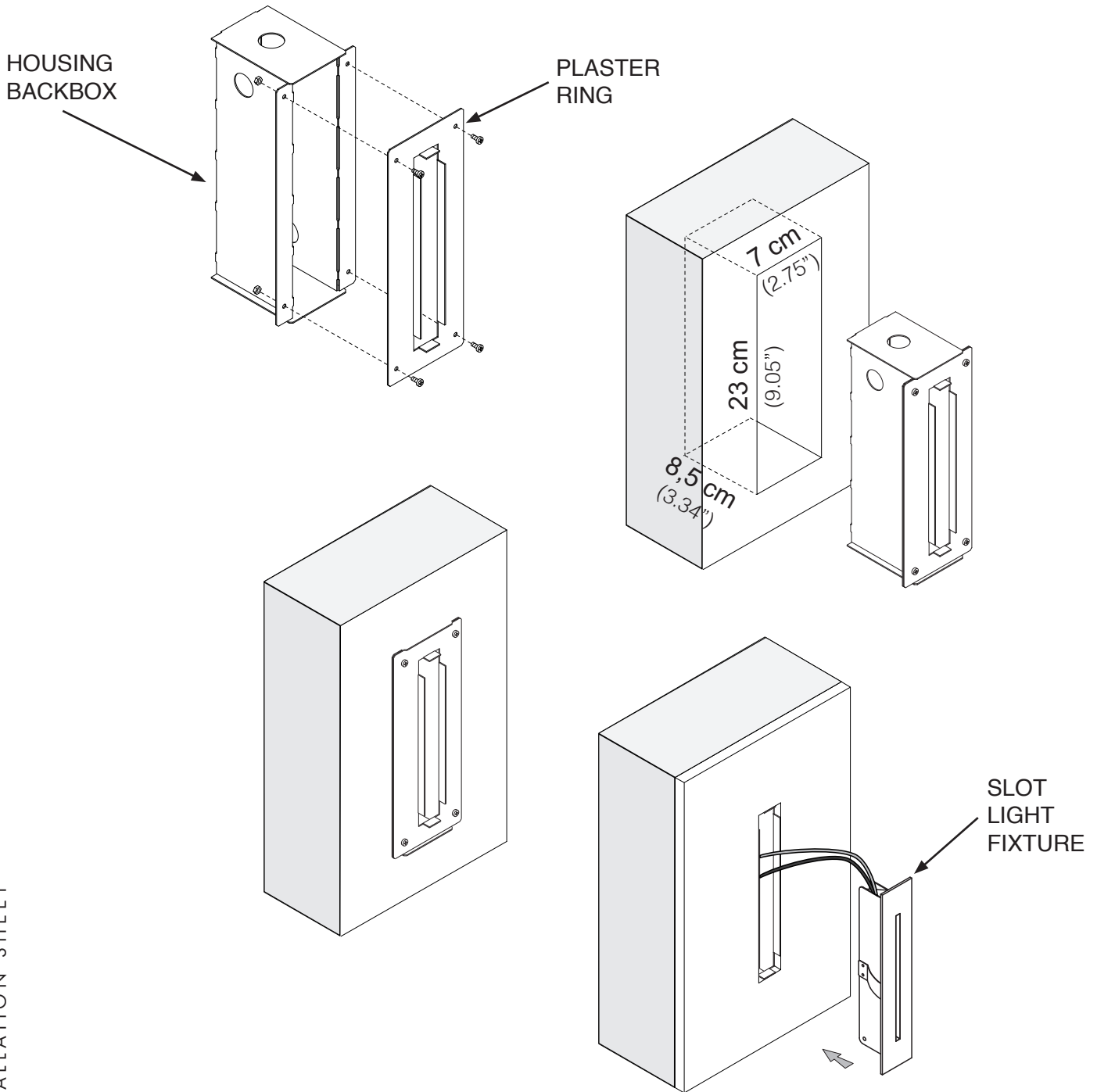

SLOT™

TYPE:

REMOTE DRIVER- INSTALLATION INSTRUCTIONS **PROJECT NAME:**

INSTALLATION FOR PLASTERBOARD - DRYWALL WITH OPTIONAL PLASTER RING

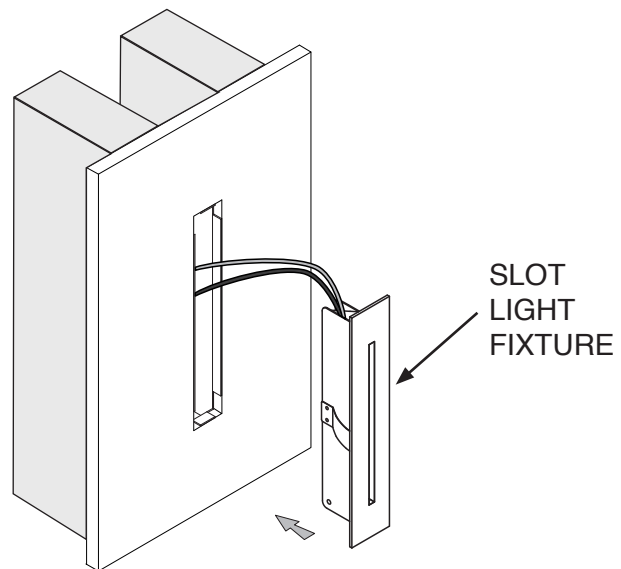
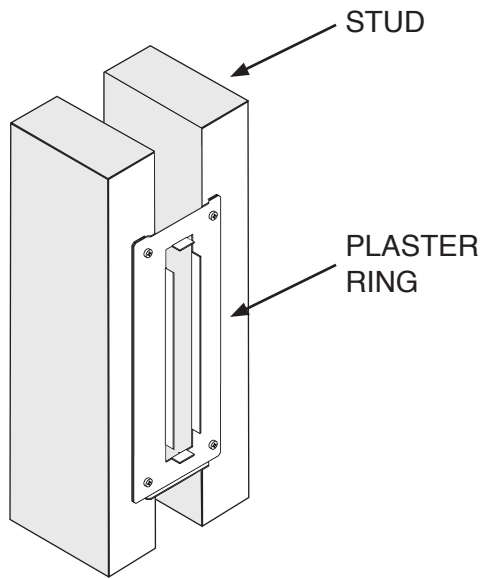

INSTALLATION SHEET

Luminart®

WWW.LUMINARTLIGHTING.COM
Last updated: 03/14/25

SLOT™

TYPE:

REMOTE DRIVER- INSTALLATION INSTRUCTIONS **PROJECT NAME:**

INSTALLATION FOR PLASTERBOARD - DRYWALL WITHOUT PLASTER RING

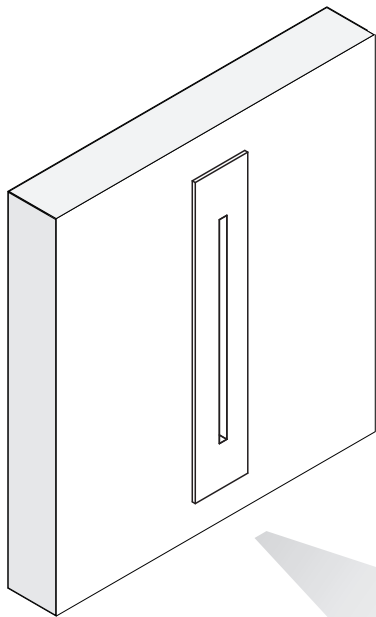
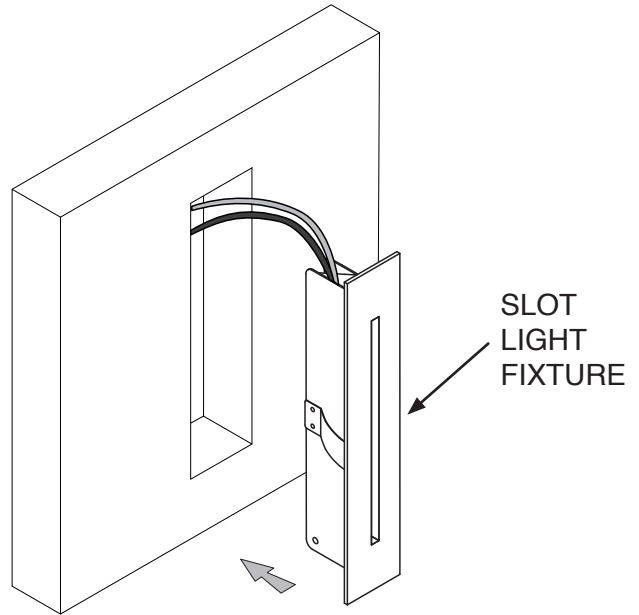
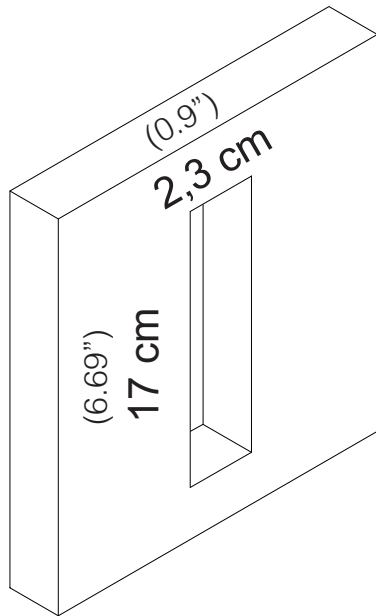

INSTALLATION SHEET

Luminart®

WWW.LUMINARTLIGHTING.COM
Last updated: 03/14/25

REMOTE DRIVER SERIES WIRING CONNECTION

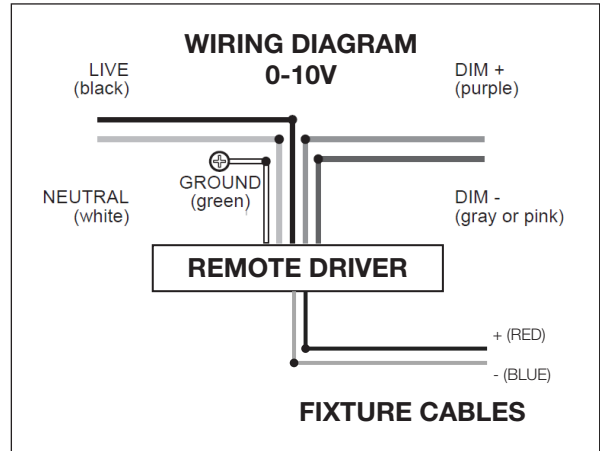
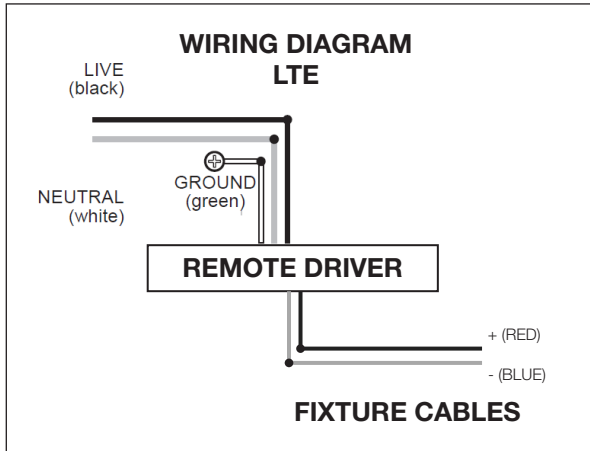

- PLEASE MAKE THE WIRE CONNECTIONS BY FOLLOWING THE WIRING DIAGRAMS ABOVE.

DRIVER INFO		
<u>4W DRIVER</u>	<u>8W DRIVER</u>	<u>12W DRIVER</u>
4W 350mA	8W 350mA	12W 350mA
1-3 FIXTURES	3-7 FIXTURES	6-11 FIXTURES

- PLEASE FOLLOW THE SERIES WIRING CONNECTION DRAWING BELOW TO MAKE THE CONNECTIONS BETWEEN THE FIXTURES AND CONNECT TO THE REMOTE DRIVER (1 DRIVER CAN BE CONNECTED TO UP TO 10 FIXTURES).

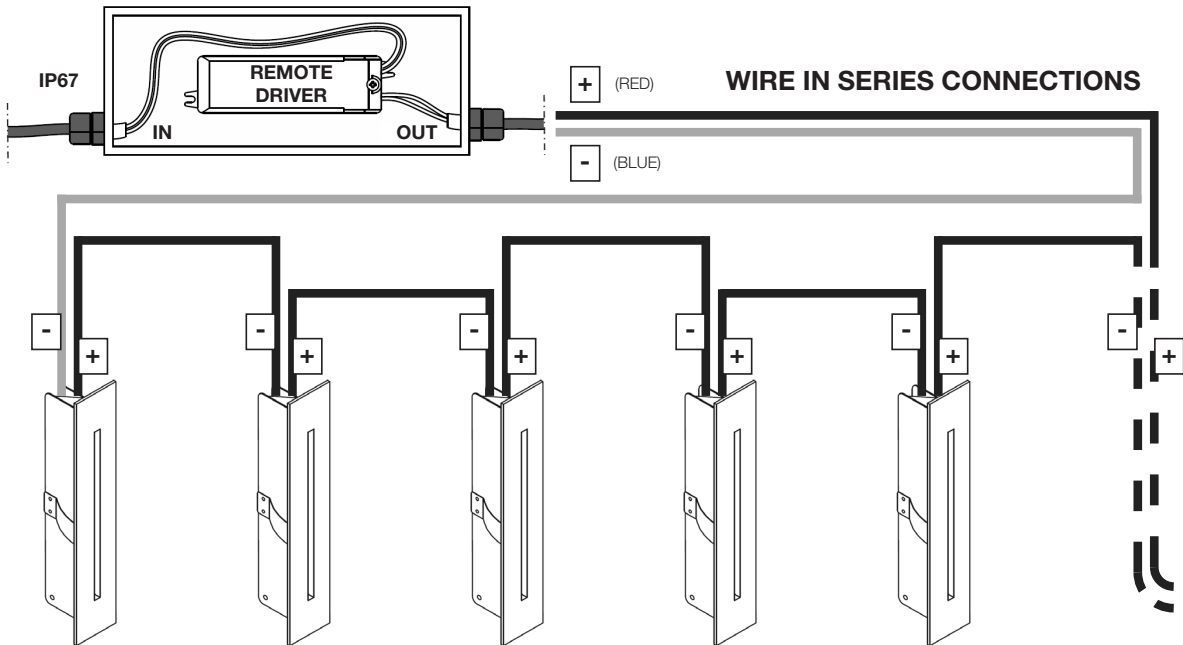

UP TO 11 FIXTURES
PLEASE SEE DRIVER INFO

INSTALLATION SHEET